

# DRIVE 12

## Self Propelled Vertical Mast Lift

Innovative solutions to low-level working at height



**Pop-Up** is the world leader in the development of low level scissor lifts, which provide a cost-effective new way to safely work at height indoors.

Designed to withstand the demands of construction sites and industrial applications, the **Pop-Up DRIVE 12** is robust, easy to use and simple to maintain.

- ▶ Drive from the platform, even while elevated
- ▶ Easily passes through a standard doorway
- ▶ No outriggers or stabilisers required
- ▶ Durable design for tough site conditions
- ▶ Working height of 5.7m
- ▶ Proven benefits over other access products:
  - better job site productivity
  - safer and more convenient working conditions
  - better return on investment (ROI) for rental/hire companies



# DRIVE 12

## Self Propelled Vertical Mast Lift

Dimensions	DRIVE 12
Max. working height	5.7m
Max. platform height (A)	3.7m
Platform size (inside)	0.74m x 1.04m
Overall width (B)	0.76m
Overall length (D)	1.36m
Stowed height (C)	1.7m
Ground clearance	76mm

Performance	
Platform capacity (SWL)	227kg
Max. operating wind speed (1 person on platform)	12.5m/s
Max. drive height	3.7m
Max. drive speed (stowed)	3.6km/h
Max. drive speed (elevated)	0.8km/h
Raise/lower time	18/25 sec
Gradeability	25%
Inside turning radius	0.37m
Outside turning radius	1.4m
Tires	305mm. dia. solid rubber, non-marking
Parking brake	2 wheel, spring-applied, hydraulically-released with manual overdrive
Drive system	dual front hydraulic motors
Controls	proportional

Power	
Power source	24V 4hp DC electric motor 4-220 Ah batteries
Battery charger	90V - 240V - 18 amp automatic

Weight	
Gross weight	776kg

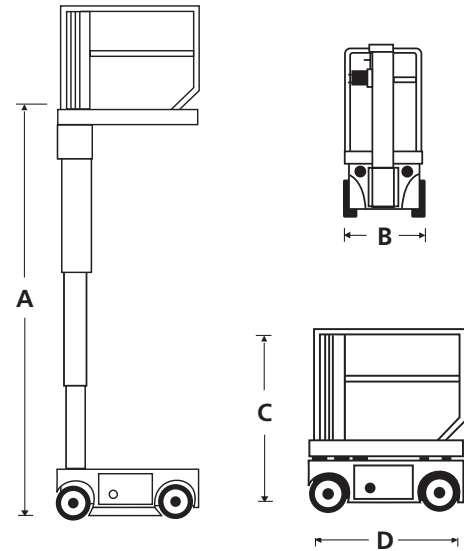

### STANDARD FEATURES

- Proportional controls
- Descent and tilt alarms
- High amp hour rating gives long usage between charges
- Emergency lowering at chassis controls
- Non-marking, solid rubber tyres
- Tie down points
- 2 persons + equipment capacity indoors
- 1 person + equipment capacity outdoors
- Selectable motion alarm
- CE approved

### OPTIONS

- Special paint colours
- Environmental green oil

### TURNING RADIUS

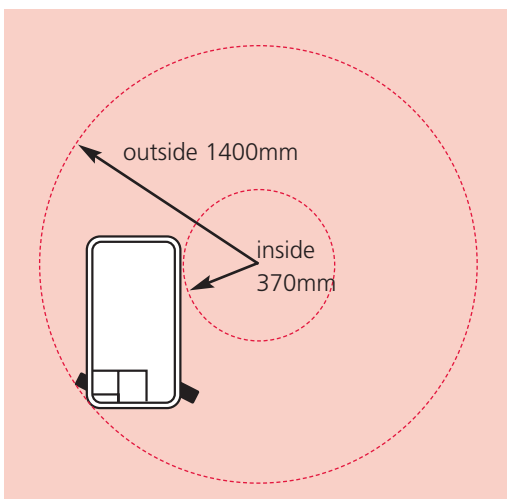

**Pop-Up Products Limited**  
 2 Deeside Point, Tenth Avenue,  
 Deeside Industrial Park,  
 Deeside, CH5 2UA. U.K.  
 Tel: +44 (0)1244 833 933  
 Fax: +44 (0)1244 833 934  
 E-mail: [contact@popupproducts.co.uk](mailto:contact@popupproducts.co.uk)