



Elevating Work Platform

Operator's Safety and Maintenance Handbook

dual use machine: with and without stabilisers (auto brakes fitted)



At **Pop-Up Products** we welcome any feedback and suggested improvements for our products. Please email us at **feedback@popupproducts.co.uk**

You can also download a copy of this handbook online at **www.popupproducts.co.uk**

Pop-Up+ Operator's Safety and Maintenance Handbook

Contents

Section 1	Page	Section 5	Page
DESCRIPTION		MAINTENANCE	
Introduction	3	Safety during maintenance	15
Description	3	Periodical maintenance and checks	15/16
Intended use	3	Storage	16
Training	4	Lubrication	16
Modifications	4	Hydraulic oil	17
Terminology	5	Electrical schematic	18
		Hydraulic schematic	19
		Troubleshooting	20
Section 2		Section 6	
SPECIFICATION		TRANSPORT INSTRUCTIONS	
Technical data	6	Lifting	21
Operating site	7	Preparation for transport	21
Noise and vibration	7	Loading and unloading	22
Limitations	7		
Section 3		Section 7	
SAFETY RULES		MAINTENANCE AND REPAIR RECORD	
Safety Rules	8	Maintenance and repair record	23
		Notes	24
Section 4		Daily checks – operator checklist	25
OPERATING INSTRUCTIONS			
Daily checks	9		
Manoeuvring the platform	9		
Engaging the brakes	10		
Auto brakes	10		
Deploying the stabilisers	10		
Stowing the stabilisers	10		
Battery isolation switch	11		
Entering and leaving the platform	12		
Control pendant	12		
Emergency stop	13		
Emergency lowering	13		
Emergency plunger valve	14		
Battery charging	14		

Introduction

This handbook provides information on the safe operation of this work platform. Operators should read and understand all of the information contained within this manual prior to operating the work platform.

The handbook contains several warnings, these indicate situations which if not avoided could result in serious injury or death to persons, or damage to the machine or property.

Additional copies of this handbook are available from the manufacturer at the address below. Information contained in this handbook is based on the latest product information at time of publication.

Pop-Up Products Ltd operate a policy of continuous improvement and therefore reserve the right to make product changes at any time without obligation.

Description

The **Pop-Up+** is a scissor lift type work platform, which is manoeuvred manually into work positions and elevated and lowered using an electro-hydraulic control system.

The standard machine includes the following standard features:

- **240kg safe working load**
- **4.5 metre working height**
- **1.72 metre stowed height**
- **Easily manoeuvrable**
- **Pass through standard doors**
- **Simple operation**
- **Steel guard rails**
- **Non-slip platform**
- **Steerable wheels**
- **Manual brakes on rear swivel wheels**
- **Auto brakes on front fixed wheels**
- **Anti-crushing lowering delay**
- **Integral battery charger**
- **Emergency lowering facility**
- **Easily transportable**
- **Low maintenance**
- **Complies with EN280:2001**
- **Stabilisers (optional if auto brakes fitted)**

Intended use

The machine has been designed to comply with the safety requirements of the Machinery Directive 2006/42/EC taking guidance from the European Standard BS EN280:2001 + A2:2009 Mobile Elevating Work Platforms.

The machine is intended to be used to lift persons, plus essential tools and materials, to enable work to be undertaken at height. Typical applications will include maintenance, cleaning, painting, etc. at varying heights above ground level.

WARNING

THE MACHINE MUST NOT BE USED IN APPLICATIONS OR FOR USES OUTSIDE OF THE SCOPE OF THIS HANDBOOK. SHOULD A CERTAIN APPLICATION NOT BE COVERED, THEN THE MANUFACTURER SHOULD BE CONTACTED

Training

It is essential that persons operating this **Pop-Up+** are fully trained in the setting up, safe use and inspection of the machine. Please download a copy of our free **Pop-Up & Pop-Up+ Familiarisation Guide** from www.popupproducts.co.uk. The guide has been designed to assist competent people in safely operating our range of low-level push around scissor lifts.

WARNING

OPERATION OF THIS MACHINE BY UNTRAINED OPERATORS MAY
RESULT IN SERIOUS INJURY OR DEATH

Modifications

No modifications must be made to this machine unless the manufacturer has given full written approval. If in doubt contact the manufacturer for advice.

Manufacturer's address:

Pop-Up Products Limited

2 Deeside Point

Tenth Avenue

Deeside Industrial Park

Deeside

CH5 2UA

UK

Tel +44 (0)1244 833 933

Fax +44 (0)1244 833 934

Email feedback@popupproducts.co.uk

www.popupproducts.co.uk

Terminology

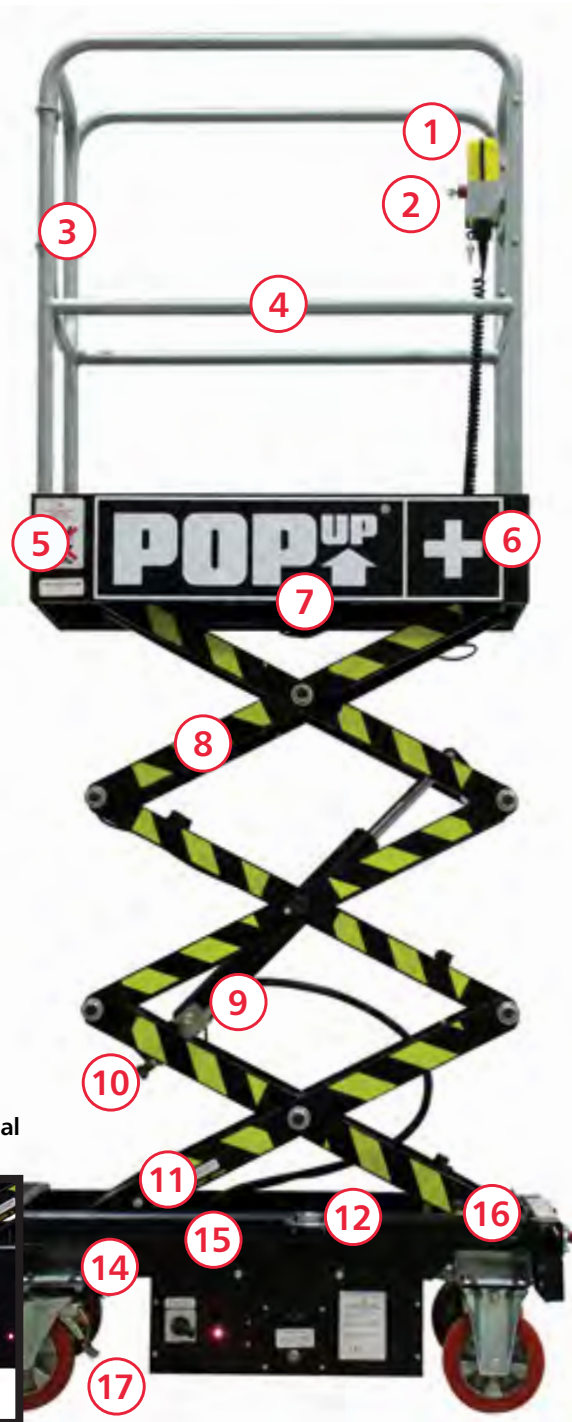

Stabilisers are optional
if auto brakes fitted

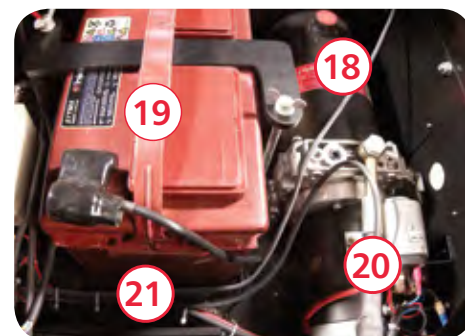

- 1. Control pendant
- 2. Emergency stop button & key
- 3. Gate
- 4. Guard rail
- 5. Handbook
- 6. Platform
- 7. 110V and 240V charger leads
- 8. Scissor pack
- 9. Main lift cylinder

- 10. Emergency plunger valve
- 11. Maintenance props
- 12. Bubble spirit level
- 13. Stabilisers
- 14. Forklift pocket (1 of 4)
- 15. Chassis
- 16. Auto front brakes
- 17. Manual brake (1 of 2)
- 18. Hydraulic tank

- 19. Battery
- 20. Hydraulic pack
- 21. Battery charger
- 22. Chassis plate
- 23. Battery condition meter
- 24. Battery charging indicator
- 25. Battery charger socket
- 26. Power selector
- 27. Emergency lowering valve

Technical data

Safe working load (SWL) equivalent to	240kg 1 person + 160kg tools and materials
Maximum platform height Maximum working height	2.5 metres 4.5 metres
Platform length Platform width Platform guard rail height Toe board height	1.01 metres 0.52 metres 1.10 metres 0.15 metres
Maximum allowable manual force Maximum allowable wind speed Maximum allowable chassis inclination	200 Newtons 0 metres/sec* 0 degrees
Electrical system Motor Batteries Battery charger	12 volt DC 0.7 kW 1 x 80 Ah Universal 90V to 240V AC
Hydraulic system Maximum pressure Reservoir capacity	13 MPa 1.22 litre
Function speeds (approx.) Raise Lower Approx. no. of lifts (fully charged with SWL)	24 seconds 25 seconds 120
Overall length Overall height (stowed) Overall width (with stabilisers deployed) Overall width (without stabilisers)	1.26 metres 1.72 metres 1.30 metres 0.70 metres
Overall mass (GVW) without stabilisers Overall mass (GVW) with stabilisers Weight (without stabilisers) Maximum wheel load	343kg 365kg 343kg 350kg

*For use in indoor exposed areas up to 12.5m/sec wind speed – pack available on request

Operating site

Select a site for the machine from which the platform will be able to reach the required work area. A visual inspection of the operating site should be made before setting up the machine. Particular attention should be given to the following items:

1. Ground conditions

Ensure that the ground on which the **Pop-Up+** is to operate is capable of supporting the weight of the machine (including the weight of the operator plus tools and materials). Be aware of floors or coverings (e.g. manhole covers) that may not withstand point loadings exerted by the castor wheels. In indoor exposed areas with wind speeds up to 12.5m/sec the **Pop-Up+** can be used with a stabiliser pack. An interlock system ensures that the stabiliser beams and legs are fully deployed before the work platform can be raised. It is essential that each of the four stabiliser feet are located on firm, solid ground. The **Pop-Up+** auto brake kit enables the removal of stabilisers for use in 0m/sec wind conditions.

2. Ground flatness

The **Pop-Up+** must only be operated on flat (0° chassis inclination) and level surfaces. The allowable chassis inclination is indicated when the spirit level bubble is within the marked limits. All castor wheels must be in full contact with the ground.

3. Obstructions

When manoeuvring, raising and lowering, ensure that there are no obstructions or persons that may be struck by the platform.

Noise and vibration

Noise levels emitted from this machine do not exceed 70 dB(A). Hand and arm vibration experienced on this machine does not exceed 0.5 m/s².

Limitations

The **Pop-Up+** is limited to operation indoors. The machine must not be used outdoors. Please consult the manufacturer if you are unsure of any application for which the machine is to be used.

This machine has been tested for Electromagnetic Compatibility (EMC) however, operation near to high powered radio transmission apparatus (e.g. radar, antennae) or within strong electrical and/or magnetic fields may affect some features of this product

WARNING

THIS MACHINE HAS NOT BEEN DESIGNED FOR OPERATION WITHIN POTENTIALLY EXPLOSIVE ATMOSPHERES

WARNING

THIS MACHINE IS NOT ELECTRICALLY INSULATED AND MUST NEVER BE USED FOR LIVE LINE WORKING. DEATH OR SERIOUS INJURY CAN RESULT FROM CONTACT WITH, OR INADEQUATE CLEARANCE FROM, ELECTRICAL CONDUCTORS

Safety Rules

- NEVER** Exceed the rated capacity (Safe Working Load or SWL) of the platform (240kgs).
 - NEVER** Use the **Pop-Up+** as a 'crane' (e.g. by suspending loads from beneath the platform).
 - NEVER** Make any attempt to increase the working height or outreach of the platform (e.g. by use of stepladders in the platform).
 - NEVER** Operate the **Pop-Up+** if the bubble spirit level is outside the marked limits.
 - NEVER** Manoeuvre the **Pop-Up+** on an inclined surface otherwise it may become uncontrollable.
 - NEVER** Manoeuvre the **Pop-Up+** whilst in its elevated position, as this may cause instability.
 - NEVER** Manoeuvre the **Pop-Up+** with a person or materials in the platform.
 - NEVER** Enter or exit the platform unless the platform is in the lowered and transport position.
 - NEVER** Apply external side loads to the platform or scissor structure.
 - NEVER** Allow persons at ground level to operate the controls whilst the platform is occupied (unless in an emergency situation).
 - NEVER** Operate the **Pop-Up+** outdoors.
 - NEVER** Attempt to overreach.
 - NEVER** Interfere with, wedge or attempt to override hydraulic, electrical or mechanical safety devices.
-
- ALWAYS** Check that there are no obstructions or persons that may be struck by the platform before and during the raising and lowering of the platform.
 - ALWAYS** Ensure that the access gate is closed once the operator has entered the work platform.
 - ALWAYS** Ensure that another responsible person on site knows how to use the emergency controls.
 - ALWAYS** Undertake the daily checks recommended in this handbook prior to operation of the machine.
 - ALWAYS** Ensure that all instructions, warning and Safe Working Load decals are clean and legible.
 - ALWAYS** Ensure the **Pop-Up+** is positioned on adequate ground to support the weight of the machine.
 - ALWAYS** Ensure that sufficient clearance is given if working near to live conductors.
 - ALWAYS** Ensure the manual rear brakes have been engaged before elevating the work platform.
 - ALWAYS** Ensure that auto front brakes are functioning correctly before attempting to use the machine.
 - ALWAYS** Ensure that the platform does not come into contact with fixed objects (e.g. buildings, etc.) or moving objects (e.g. vehicles, other plant equipment, etc.).
 - ALWAYS** Replace any removable guard rails (e.g. close and lock access gate) to enable full edge protection to be maintained.
 - ALWAYS** Ensure that the load is evenly distributed within the platform.
 - ALWAYS** Ensure the safety of persons that may enter the area around the platform (e.g. cordon off the area to prevent persons entering the danger area).
 - ALWAYS** Ensure hands are kept within the confines of the guard rails whilst elevating the work platform.

Daily checks

Prior to operating the **Pop-Up+**, the following items must be checked:

- **Structure (e.g. damage, cracks, corrosion, abrasion, welds, connections)**
- **Platform (floor, rails)**
- **Castors (smooth movement, damage)**
- **Rear manual brakes**
- **Auto front brakes**
- **Hydraulic oil**
- **Oil leaks**
- **Battery condition**
- **Raise and lower functions (including descent delay) ***
- **Emergency stop and lowering functions**
- **Limit switch**
- **Safety decals**
- **Stabilisers (optional if Pop-Up+ is fitted with auto brakes)**

* The raise and lower functions can be tested by removing the upper control box from its holder in the work platform and using the controls whilst at ground level. (**NOTE:** unless in an emergency situation, this practice must not be employed when a person is in the work platform).

If the above checks reveal malfunctions or damage on the **Pop-Up+**, then the machine must not be used until the problem is rectified. If in doubt, seek further assistance from the manufacturer.

If safety decals are no longer legible or missing, please contact the manufacturer for replacements.

The **Daily Checks** page in Section 7 of this handbook may be photocopied to provide an aide memoir for operators when undertaking these important checks.

WARNING

BEFORE OPERATING YOUR **POP-UP+**, YOU MUST ENSURE THAT YOU HAVE BEEN ADEQUATELY TRAINED IN ITS USE AND HAVE FULLY READ AND UNDERSTOOD THIS OPERATOR'S HANDBOOK, PAYING PARTICULAR ATTENTION TO **SECTION 3 - SAFETY RULES**

Manoeuvring the platform

Manoeuvre the platform into position using both hands on the platform rails as shown. Take care to avoid trapping hands or feet whilst manoeuvring the platform.

Never manoeuvre the **Pop-Up+** whilst it is elevated or with a person, tools or materials in the platform.



Engaging the brakes

Always ensure that both rear manual castor brakes are engaged before elevating the work platform to prevent any inadvertent movement. The brakes are engaged by pushing down on the lever as shown. Releasing the brake is simply a reversal of the engaging procedure. Before operating please ensure that both of the manual rear brakes are engaged.



Engage



Release



Auto brakes

Auto brakes

On the latest models **Pop-Up+** is fitted with a secondary automatic brake system acting on the front fixed wheels. **Pop-Up+** does not require stabilisers if these auto brakes are fitted. An auto brake kit is available to purchase. This system should be checked for functionality before attempting to use the machine. To check, leave the rear manual brakes 'OFF' and elevate the machine approximately 150mm. Hold the handrail on both sides at the gate end and attempt to push the machine. It should be difficult to push the machine if the auto brakes are functioning correctly. Please consult the manufacturer if the machine is easily pushed. Before operating please ensure the manual rear brakes are engaged. An auto brake kit is available for **Pop-Up+** for the safe removal of stabilisers.

Stabilisers

Deploying the stabilisers

Models of **Pop-Up+**, without auto brakes, are fitted with four stabilisers, one at each corner. All four stabilisers must be fully deployed before the platform can be raised, as follows:

1. Pull out the red knob on the stabiliser beam housing
2. Extend the beam until it locks into position
3. Pull out the blue plunger on the stabiliser leg so that the foot drops to the ground
4. Ensure that the plunger pin engages into the radial slot at the top of the leg
5. Wind the handle clockwise until it is hand-tight
6. Ensure that the yellow stabiliser indicator lamp is lit

Once the stabilisers are in position, the platform can be raised to the desired height.

Retracting and stowing the stabilisers

When work is finished on the **Pop-Up+**, the platform should be lowered into its resting position and the worker should exit the platform. Only then should the stabilisers be retracted and stowed. To do so:

1. Turn the handle anti-clockwise to loosen the stabiliser foot
2. Pull out and hold the blue plunger
3. Lift the stabiliser leg until it is in the raised position
4. Release the blue plunger until it is seated in the radial ring around the bottom of the stabiliser leg
5. Pull the red knob on the stabiliser beam outwards
6. Push the beam back into its housing until it locks into the 'transport' position



Battery isolation switch

The **Pop-Up+** is provided with a key operated switch which is used to isolate the battery and therefore the electrical system, preventing unauthorised use. To enable the electrical system, insert the key and turn clockwise, as shown below, making sure the emergency stop button is fully released.

Ensure that when the machine is not in use, the emergency stop button is depressed and the key removed. Further electrical isolation can be achieved by selecting '0' on the power selector switch. Position '1' is for normal operation and position '2' is for charging the machine.



Entering and leaving the work platform

Always use three points of contact when entering or exiting the platform, using the handholds provided. For example, use two hands and one foot, as shown below. Use the step provided on the base of the machine.

On entering the platform, ensure that the gate is closed behind you.



Control pendant

The control pendant houses the platform raise and lower controls.

Pressing the 'UP' button raises the platform.

Pressing the 'DOWN' button lowers the platform.

To avoid crushing and shearing hazards, a delay feature is fitted which actuates when the platform is lowered to the transport position. The platform will momentarily stop to enable the operator to look around the machine to determine whether any persons are adjacent to the scissor mechanism. After a time delay, the lowering control will be enabled once more to permit the operator to continue to lower to the transport position.

Take care to avoid repeated jerky movements which could cause unnecessary impact loads on the structure.



Emergency stop

An emergency stop button is provided on the control pendant. Once depressed, this isolates power to the raise and lower functions.

To restore functionality, twist the emergency stop button clockwise to release the button, as shown below.

Turning the Power Selector to the '0' position also has the effect of isolating power to the raise and lower functions.



Emergency lowering

1. Pull out Plunger 'A' and rotate through 90 degrees.
2. Turn valve 'B' anticlockwise until platform starts to lower. To stop the platform at any time, turn valve clockwise until platform stops descending.
3. Once platform has descended fully, please ensure valve 'B' is closed off by turning clockwise.
4. Also ensure that the plunger valve is reset before operating, see instructions for plunger valve resetting.

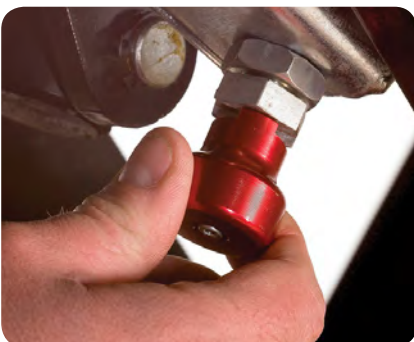

Plunger 'A'



Valve 'B'

Emergency plunger valve

The plunger valve must be reset to enable the machine to operate correctly. To reset the valve firstly ensure Valve 'B' has been fully closed. Depress the raise button on the pendant control and raise the platform until the maintenance stands can be deployed. Once the stands have been deployed simply pull Plunger 'A' and turn through 90 degrees. Push the plunger back into the slot as shown left.

Depress the raise button once again and reset the maintenance stands. The machine is now able to operate correctly.



Battery charging

A battery condition meter is fitted to the **Pop-Up+** as shown. This meter displays the amount of charge in the battery. To accurately check the battery condition, a load must be applied across the battery, elevating the machine from ground level will achieve this. Stand away from the machine with the control pendant and press the UP button whilst observing the bars on the meter. All bars illuminated shows that the battery is fully charged. If less than four bars are on the display, the battery requires charging.

The **Pop-Up+** is supplied with a dedicated battery charger, which is separate to the machine. Do not use any other type of battery charger to charge your **Pop-Up+** machine.

To charge the battery, follow these steps:

1. Turn the power selector switch to '0' (OFF) position.
2. Connect either the 240V or 110V lead (depending on mains supply) to the **Pop-Up+** at the point shown.
3. Connect the mains lead to a suitable power supply (either 110V or 240V)
4. Turn the power selector to '2' (CHARGE) position and leave the charger to complete the charging cycle. It will shut off automatically once finished. The battery should be fully recharged after a period of 12 hours, which is indicated by the 95% light illuminating on the battery charging indicator panel as shown.



Safety during maintenance

When performing maintenance on the **Pop-Up+** with the platform elevated, always ensure that the maintenance props are engaged as shown.



WARNING

FAILURE TO ENGAGE THE MAINTENANCE PROPS MAY RESULT IN THE PLATFORM LOWERING WITHOUT WARNING

Periodical maintenance and checks

The following checks should be undertaken at the recommended intervals shown:

	Daily/Pre-use	Monthly	6 Monthly	12 Monthly
Inspect structure	●	●	●	●
Inspect platform	●	●	●	●
Check castors	●	●	●	●
Check manual rear brakes function	●	●	●	●
Check auto brakes function	●	●	●	●
Inspect for oil leaks	●	●	●	●
Check battery condition	●	●	●	●
Check raise/lower functions	●	●	●	●
Check emergency stop	●	●	●	●
Check emergency lower	●	●	●	●
Check stabilisers and lights function	●	●	●	●
Inspect training card and safety decals	●	●	●	●
Check hydraulic oil level		●	●	●
Inspect limit switches		●	●	●
Inspect wiring		●	●	●
Check electrical connectors		●	●	●
Lubricate roller guides		●	●	●
Lubricate grease nipples		●	●	●
Lubricate pivot pins			●	●
Lubricate castor mounts			●	●
Replace hydraulic oil				●

Periodical maintenance and checks (continued)

Prior to first use of the **Pop-Up+**, all daily/pre-use checks must be undertaken. If the machine has been in storage for a long period of time, it may be necessary to undertake additional checks and tests as per the table on the preceding page (e.g. lubrication, hydraulic oil, battery condition).

The Lifting Operations and Lifting Equipment Regulations 1998 (LOLER) require that lifting equipment for lifting persons must be THOROUGHLY EXAMINED every six months.

Following any maintenance on the **Pop-Up+**, a full function test should be undertaken to ensure correct operation of the machine.

It is essential that only manufacturer's approved replacement parts are used when maintaining and servicing the **Pop-Up+**. Failure to do so may result in an unsafe or unstable machine.

Storage

The electrical components of this **Pop-Up+** are not protected from external weather conditions and the machine should therefore not be stored outdoors. Storage in a clean, dry indoor environment is recommended.

Frequent checks on the condition of the machine should be made to ensure no excessive deterioration occurs due to the environment in which the machine is housed.

Lubrication

The required lubrication points are shown opposite.

Lubrication points are to be found on the end of the scissor pack at both ends of the machine.

The lubricant recommended for use with this **Pop-Up+** is:
standard machine grease

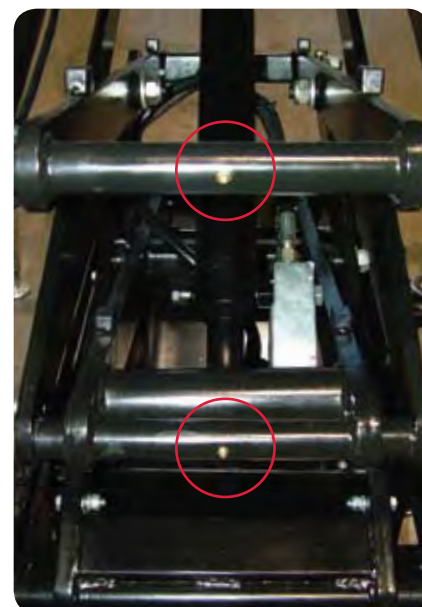

Hydraulic oil

The hydraulic oil level can be checked by removing the filler cap. The correct amount of oil is in the tank when the tip of the level rod has hydraulic oil on it. This check must be carried out on a level surface.

The hydraulic oil can be topped up by adding oil to the filler as shown below. Take care not to spill hydraulic fluid over any of the surrounding machine components.

The hydraulic oil can be drained by removing the tank. Remove the bolts as shown above and separate the tank from the pump body. The hydraulic fluid can then be correctly disposed of.

Reassembly is the reverse of above.



Filler cap



Bolts

The hydraulic oil recommended for use with this **Pop-Up+** is:
mineral basis hydraulic oil with lubricating, antifoaming, anti-corrosive, antioxidant HL-HLP (ISO and UNI HM)-HV-HLPD performances according to DIN51524 part 1-2 standards

Minimum viscosity	15cts (23°E / 77, 39 SSU at 100°F)
Max. viscosity at starting up	800cts (105,6°E / 3708 SSU at 100°F)
Max. working viscosity	100cts (13,2 E / 463,5 SSU at 100°F)
Suggested viscosity range	25 ÷ 40 cts = (3,47 ÷ 5,35° E / 119,3 ÷ 186,3 SSU a 100°F)
Allowed temperature	Max 80°C (176°F)
Recommended temperature	30 ÷ 60°C (86 ÷ 140°F)

Electrical schematic

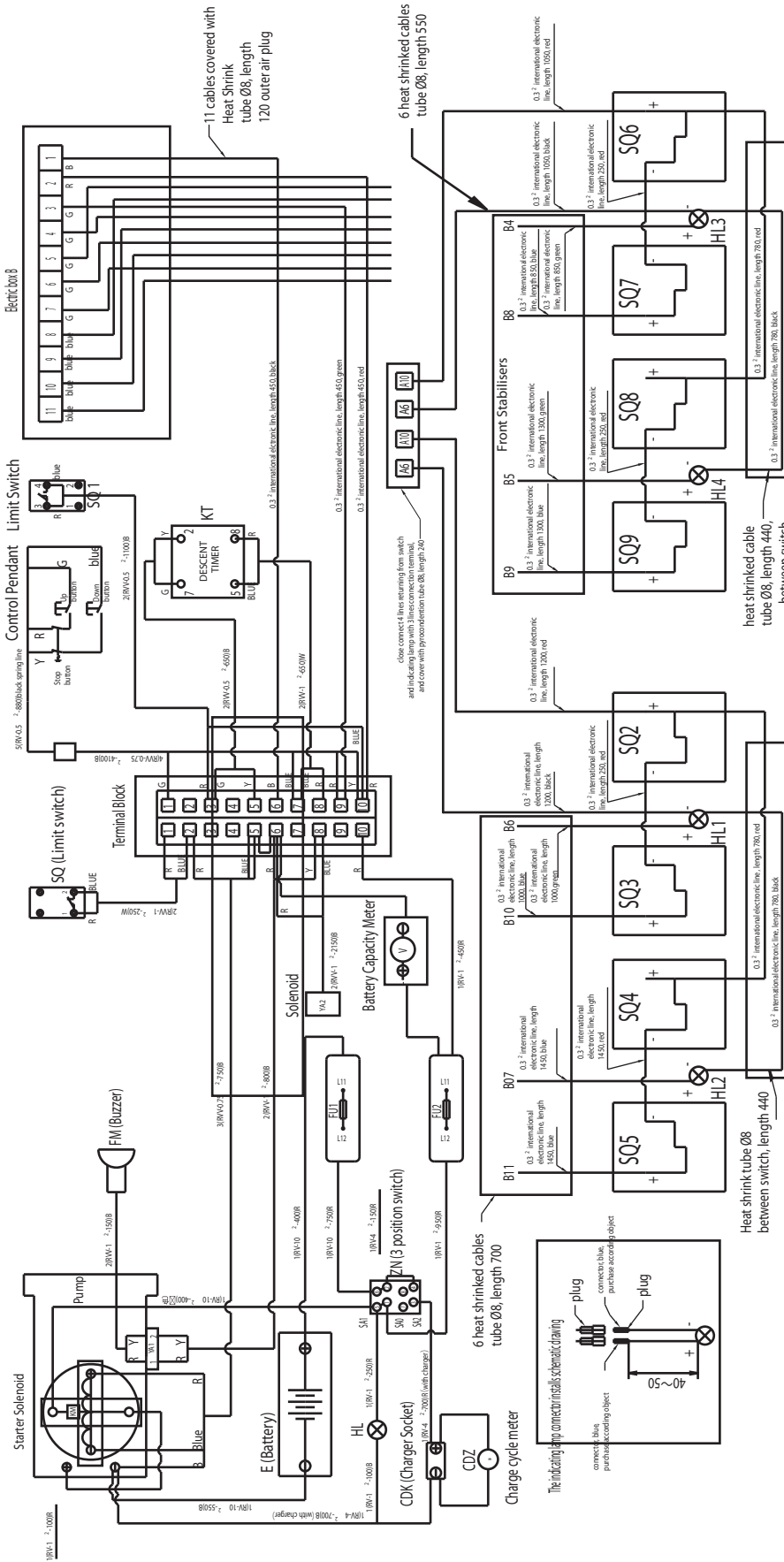
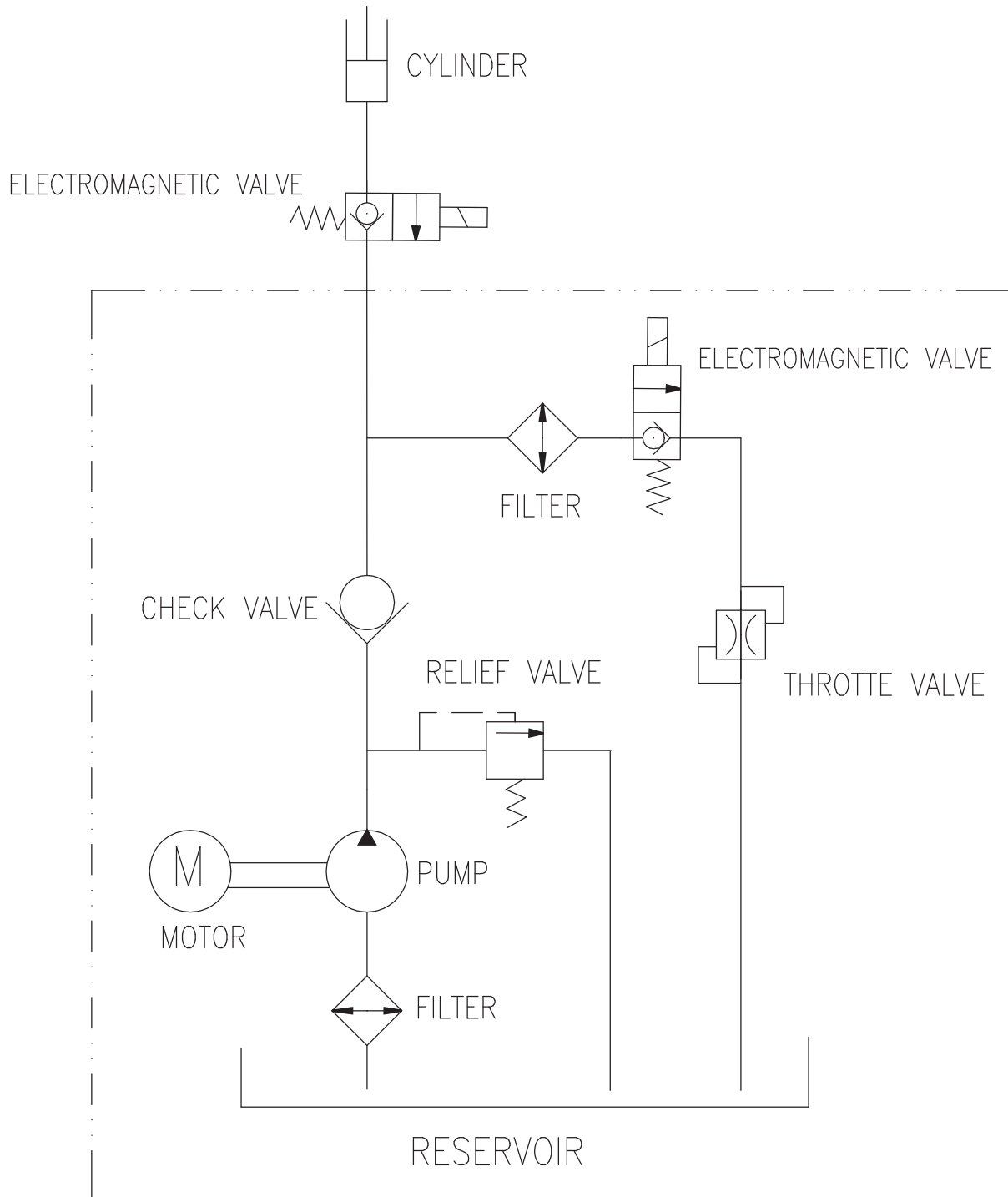

Diagram Key		
Article No.	Description	Qty
HL1 - 4	LED Indicator	4
SQ2 - 9	Stabiliser Switch	8
SQ	Stroke Limit Switch	1
SQ1	Descent Delay Trip Switch	1
KT	Timer Relay	1
FM	Buzzer	1
AN3	Emergency Stop	1
YA1 - 2	Solenoid	2
AN2	Descent Button	1
AN1	Lifting Button	1
FU2	Fuse 10amp	1
ZN	Isolator Switch	1
M	DC Motor	1
FU1	Fuse 63amp	1
KM01A - KM01B	Magnetic Switch	1
HL1 -	Power Indicator	1
CDZ	Charge Indicator	1
CDK	Charger	1
V	Battery Condition Meter	1
E	Battery	1



Troubleshooting

Problem	Cause	Repair
Platform does not raise (motor not running)	1. Faulty wiring	1. Check the wiring referring to the electrical schematic
	2. Battery is disconnected	2. Reconnect the battery
	3. Battery charge is insufficient	3. Charge the battery
Platform does not raise (motor running)	1. Faulty adjustment of relief valve	1. Adjust relief valve
	2. Faulty hydraulic pump	2. Replace power pack
	3. Insufficient hydraulic oil	3. Add hydraulic oil
Platform creeps (uncontrolled lowering)	1. Oil leakage in power pack	1. Replace lowering valve
	2. Oil leakage from hydraulic circuit	2. Check hydraulic circuit and repair
Oil leakage from cylinder	Faulty sealing	Replace sealing
Oil leakage from piping or joint	Insufficient tightening or seal invalid	Tighten joint again or replace seal
Oil leakage from air breather	Excessive quantity of oil	Reduce oil quantity

Lifting

No lifting attachment points are provided on the **Pop-Up+** and therefore lifting of the machine (e.g. with a crane or straps) is prohibited.

Preparation for transport

Prior to transporting the **Pop-Up+** on a vehicle, ensure that the following precautions are taken in order to avoid damage to the machine or damage to the transporting vehicle.

1. Ensure that the platform is fully lowered to its rest position.
2. Ensure that loose items (e.g. control pendant, battery charger) are secured to the platform.
3. Ensure brakes are engaged on both rear castor wheels.
4. Secure the **Pop-Up+** to the transport vehicle using straps across the platform as shown below.



Loading and unloading

When loading or unloading the **Pop-Up+**, use one of the methods shown.



Forklift



Tail lift

When using a forklift to lift the **Pop-Up+**, ensure the forks are sufficiently inserted into the forklift pockets in the base of the machine. Safety decals applied to the **Pop-Up+** show the location of the forklift pockets.

When using a tail lift to load or unload the **Pop-Up+** ensure that the manual brakes are applied to both rear castor wheels. Ensure that the capacity of the tail lift is sufficient to handle the **Pop-Up+**. Take care when manoeuvring the machine on the tail lift.

WARNING

NEVER ATTEMPT TO LOAD OR UNLOAD THE **POP-UP+** BY MANUAL EFFORT ONLY, SERIOUS INJURY, MACHINE OR PROPERTY DAMAGE COULD RESULT

Maintenance

Date	Scheduled maintenance undertaken	By

Repairs

Date	Repairs undertaken	By

Examinations/tests

Date	Examinations/tests undertaken	By

PLEASE PHOTOCOPY THIS PAGE FOR YOUR OWN USE, AS REQUIRED.

Notes

Daily checks – operator checklist

The following checklist has been provided to enable daily checks to be undertaken prior to use of this Pop-Up+. These checks should be carried out each working day or at the beginning of each shift. The purpose of the checks is to identify any wear and tear or malfunction of the machine's components and systems.

WARNING

FAILURE TO UNDERTAKE THESE CHECKS MAY RESULT IN DEFECTS ON, OR DETERIORATION OF THIS **POP-UP+** GOING UNDETECTED AND POSSIBLY RESULTING IN AN UNSAFE MACHINE

Note that Regulation 8 of the Lifting Operations and Lifting Equipment Regulations 1998 (LOLER) require that persons using lifting equipment have appropriate training and instructions to enable them to identify whether lifting equipment is safe to use.

Machine number	
-----------------------	--

1. Prior to operating the platform, the following items must be checked:

OK? (please tick)	OK? (please tick)
Structure	Battery condition
Platform	Raise and lower
Castors	Emergency stop
Rear manual brakes	Emergency lower
Front auto brakes	Limit switch
Hydraulic oil	Safety decals
Oil leaks	Stabilisers (optional if Pop-Up+ is fitted with auto brakes)

Date

Checked by

2. Use raise, lower and emergency stop functions to ensure correct operation.

Should any defects be identified in any of the above areas, these should be reported to your employer. It may be necessary to further seek assistance from the supplier of the machine, this may be the hire company or the manufacturer. You should only rectify any defects if you are authorised and competent to do so.

Do not use the machine unless each of the items above is checked and stated OK.

At **Pop-Up Products** we welcome any feedback and suggested improvements for our products.

Please email us at

feedback@popupproducts.co.uk

You can also download a copy of this handbook online at

www.popupproducts.co.uk

Pop-Up Products Limited

Call **+44 (0) 1244 833933**

Email **contact@popupproducts.co.uk**

www.popupproducts.co.uk

IPS Service, Parts & Warranty

Service **+44 (0)1952 671 400**

Parts & Warranty **+44 (0) 1952 607 660**

www.ips-ltd.biz



www.popupproducts.co.uk

Pop-Up Products Limited

2 Deeside Point, Tenth Avenue, Deeside Industrial Park, Deeside CH5 2UA

Tel +44 (0) 1244 833 933 Fax +44 (0) 1244 833 934 Email contact@popupproducts.co.uk

