

IMPORTANT SAFETY NOTES

Castors

- Prior to use expander type castors fitted to unit must be checked for tightness.
 - Expander type castors rely on the expander bolt being tightened to ensure the castors remain in situ.
 - Always ensure castors are locked in position before use.
 - Only use platform on level surface.
 - Always work within confines of guarded platform area, do not over reach.
 - Only locate platform at designated positions.
 - Do not attempt to move platform whilst in use.
 - Always ensure gate is closed securely prior to use.
 - Do not attempt to extend platform height with use of any additional items.
 - Do not attempt to locate platform on Prevention Cap.
 - Safe working load 150 Kgs, (1 man and hand tools).
- If in doubt contact your supplier.

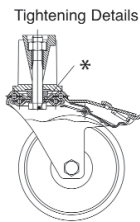

Tightening Details *This bolt to be tightened to a torque of between 30 /40 Nm and should be checked for tightness before attempting to use the equipment.

N.B.
A general guide for achieving this torque would be to hand tighten the bolt with a 19mm AF ring spanner and to then further turn the bolt by another 2 full turns



PODIUM PLATFORM

- Safer than steps
- Folds out in a minute
- Variable platform
Heights : 950mm & 1250mm
- Rigid structure
- Non-slip all aluminium construction
- Telescopic handrail
- Walk in walk out access
- Fully folding unit
- No loose components



>> WALK IN SAFETY ACCESS



>> LIGHTWEIGHT, COMPACT AND EASY TO TRANSPORT



EIGER 100

assembly sequence

Please refer to safety notes prior to use

STEP 1

Fold open unit ensuring locking pins at A & C are facing you and castor locks are disengaged. Engage locking pins by applying pressure to A, B then C respectively as shown.

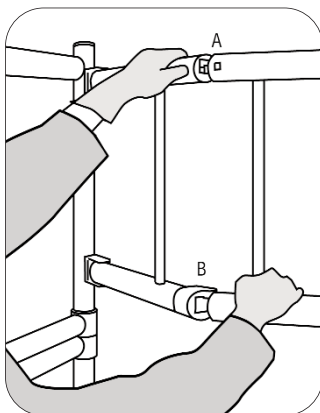

STEP 2

Unlock and relocate gate to temporary position for later use.

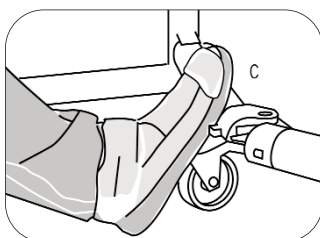

STEP 3

Disengage and extend diagonal brace by pressing both ends of Detent Pin and locate onto bottom rung opposite.

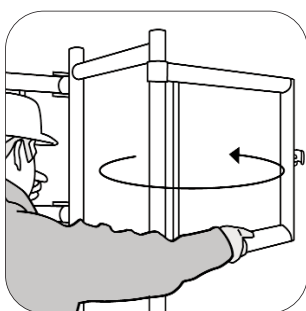

STEP 4

Locate steps by disengaging locking pin D slide step towards you and secure onto step support.

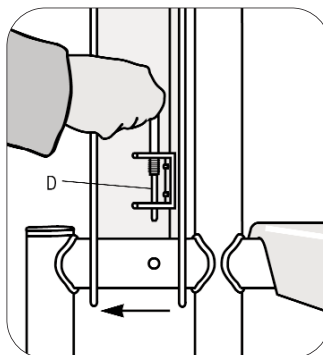

STEP 5

Lock off Castors at 45 degrees with brakes facing outwards.

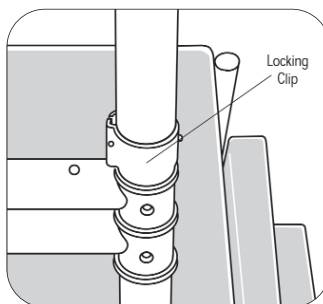

STEP 6

Disengage platform via 2 locking pins located underneath platform. Slide platform into position 1 for height of 950mm, ensuring locking pins are fully engaged.

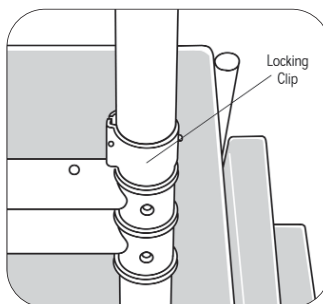

STEP 7

Access platform via steps. Close gate securely behind you to ensure a safe working environment.

STEP 8

For use at position 2 (1.25 mtr level), release locking clips and extend telescopic guard rail to upper location. Relocate locking clips. Relocate platform at position 2, close gate securely to ensure safe working environment.

