

# MI TOWER+



INSTRUCTION MANUAL EN 1004-2-en  
(Rev.07-03-03-2025)



+44 (0)1244 833 933



info@popupproducts.co.uk



popupproducts.co.uk



## CONTENTS

CONTENTS	1	GETTING STARTED	11
INTRODUCTION	2	MITOWER+ 2M - ASSEMBLY	12
KNOW YOUR MITOWER+	3	MITOWER+ 3M - ASSEMBLY	14
KNOW YOUR MITOWER+'S COMPONENTS	4	MITOWER+ 4M - ASSEMBLY	16
KNOW YOUR KIT LIST AND SPECIFICATIONS	6	MITOWER+ 5M - ASSEMBLY	18
KNOW YOUR STORAGE AND TRANSPORT PACK	7	MITOWER+ 6M - ASSEMBLY	20
SAFETY DOS AND DON'TS - ALWAYS	8	10 POINT PRE-USE SAFETY CHECKLIST	22
SAFETY DOS AND DON'TS - NEVER	9	REGISTRATIONS	23
BEFORE YOU START	10		

# INTRODUCTION

MI TOWER+ is a versatile and high quality mobile access tower providing one work platform for one person used throughout the building and construction industry for both indoor and outdoor access solutions, where a stable and secure platform is required. Ideal for maintenance and installation work or short term access. It is designed in accordance with the latest testing and quality standards. MI TOWER+ complies with BS EN 1004 -1 : 2020 and WAHR with vertical ladder access and designed for Class 3 loadings. Platform heights between 2.0m & 6.0m internal / external. Tower designation is EN1004-3-6/6-XXXD-H2.

This instruction manual is in compliance with BS EN 1004-2-en.

Verification and assessment documentation is held by POP UP Products Ltd.

Our priority is to help ensure the safe operation of our products, so please pay particular attention to the safety tips on pages 8 & 9.

We want you to enjoy the safe and responsible use of MI TOWER+ with the minimum of fuss and this guide is designed to get you up and running as quickly and as safely as possible.

We recommend that you read this guide prior to assembling and using your MI TOWER+.

This instruction manual shall be available on the location of use of your MI TOWER+.

Your MI TOWER+ shall only be used in accordance with this assembly guide without modification and national regulations.

User training courses cannot be a substitute for instruction manuals but only complement them.

This product shall only be used according to the instruction manual.

Only original Pop Up Products MI TOWER+ components, in undamaged condition as specified in this instruction manual, shall be used to assemble this access tower.

Pop Up Products Limited cannot accept responsibility in the event of an accident occurring because of mixing components from different manufacturers.

Mobile access and working towers designed in accordance with EN 1004-1 are not anchor points for personal fall arrest equipment.

Working is only permitted on a platform with complete side protection, including guardrails and toeboards.

Maximum uniformly distributed load permitted on a single platform is 240Kg, ensuring the hatch area is always kept clear of materials to allow unimpeded access to the platform.

**Visit** PASMA and HSE for further reference.

# KNOW YOUR MI TOWER+

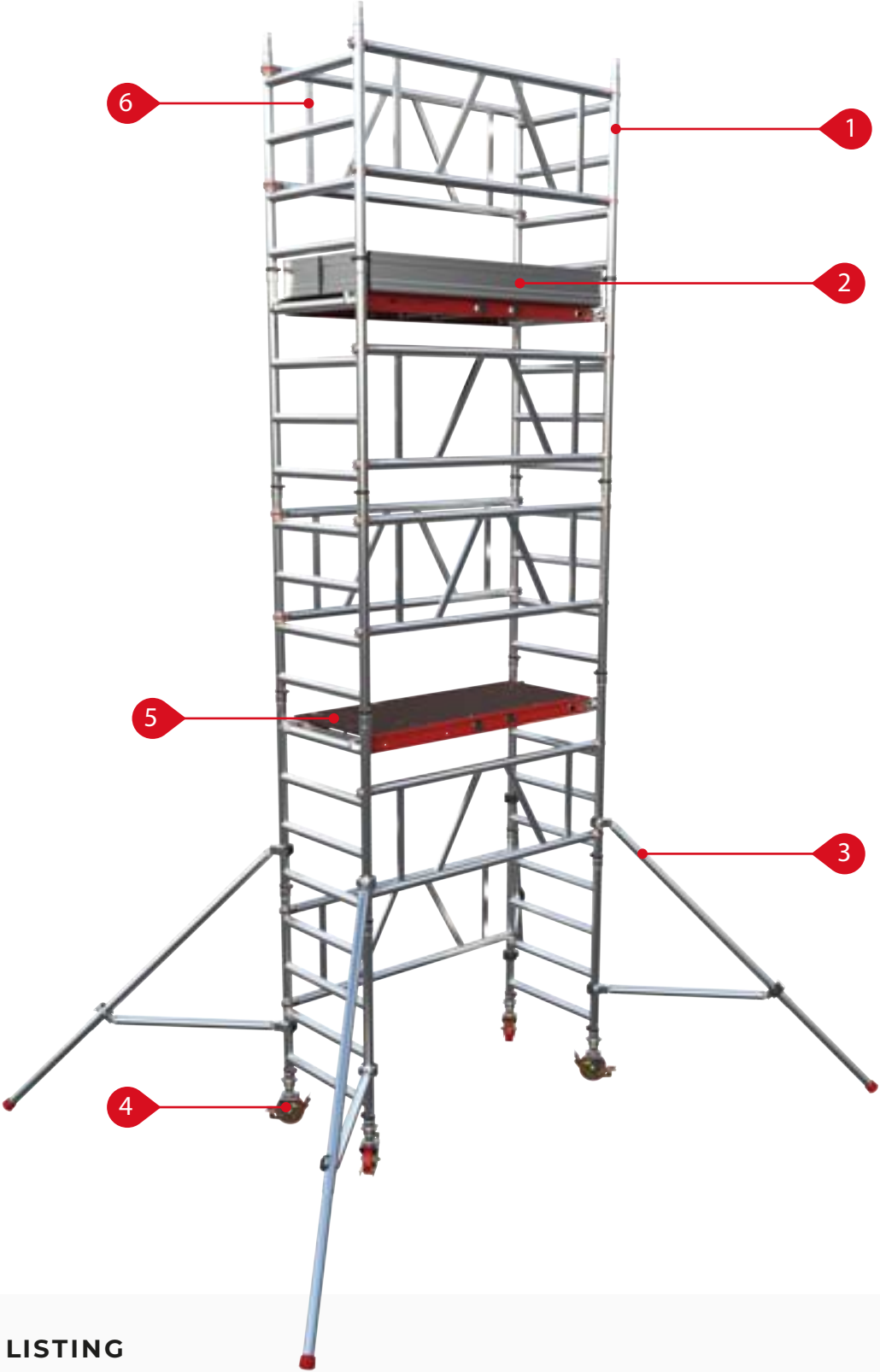

## PARTS LISTING

1	4 RUNG FRAME	4	ADJUSTABLE LEG AND CASTOR
2	TOE BOARD	5	HATCH PLATFORM
3	TELESCOPIC STABILISER	6	GUARDRAIL BRACE PANEL

# KNOW YOUR MI TOWER+ COMPONENTS

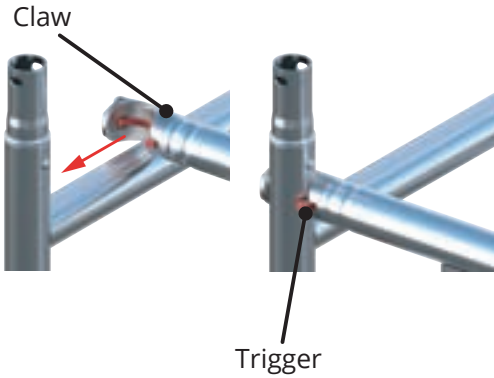

## 1 GUARDRAIL BRACE PANEL

Claws are fitted to the guardrail brace panels and each has an automatic locking jaw which is released by simply moving the jaw's trigger. The claw must only be attached to the frame with the opening facing outward. Attachment with the jaw's opening facing inward will not fully protect the user if lent upon and may cause serious injury or death. Always ensure that each claw is positively locked in position before using your tower. Removal of the guardrail brace panel is simply a reversal of the attachment sequence

## 2 FRAME CLIPS

The frame clip's pin locates into a retaining hole in the frames to lock tower sections together when placed one on top of the other. The pin is locked in place by a red tab to ensure that it remains in place. From the disengaged position, pivot the pin / tab to bring the pin horizontal. Insert the pin fully through the retaining hole with its tail pointing down. Next flip the tab, vertically, to lock the pin in place. Removal is simply a reversal of the fitting sequence.

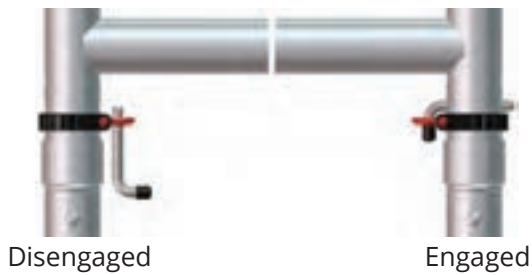

## 3 STABILISER COUPLER CLAMP

The coupler clamps are used to secure the stabilisers to the tower's vertical tubing. With the clamp jaw open, offer it to the tube. Bring the jaw around the tube and set the buckle on to the hook, then close the clamp arm to lock the stabiliser in position. A similar clamp is fitted to the stabiliser extension leg. Removal of the stabiliser coupler clamp is simply a reversal of the attachment sequence.



## 4 WIND-LOCK CATCH

The wind lock catches comprise of a set of auto-engaging hooks at one end of the platform and a single gravity type catch at the other. The purpose of these devices is to prevent up-lift of the platforms in windy conditions. To engage the auto wind lock (AWL) simply tilt the platform at the angle shown before placing the hooks onto the rung of the end frame. Lower the opposite end of the platform onto the opposite end frame rung and the gravity type lock will automatically engage. Simply lift and hold the gravity lock before tilting the platform to dis-engage the opposite AWL hooks when removing the platform on tower disassembly.



## 5 PLATFORM WITH BUILT IN COMPONENT HANGERS

To enable one man to erect MI TOWER products, each hatch is fitted with four component hangers which are stowed (two either side) within the platform's frame. The hangers can be extended when needed and retracted when not.

To extend a hanger simply pull up the friction clip and pull the component hanger until it stops. To retract the hanger, simply reverse the procedure.

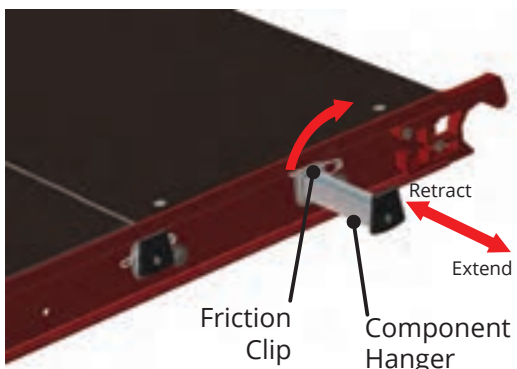

## KNOW YOUR MITOWER+ COMPONENTS

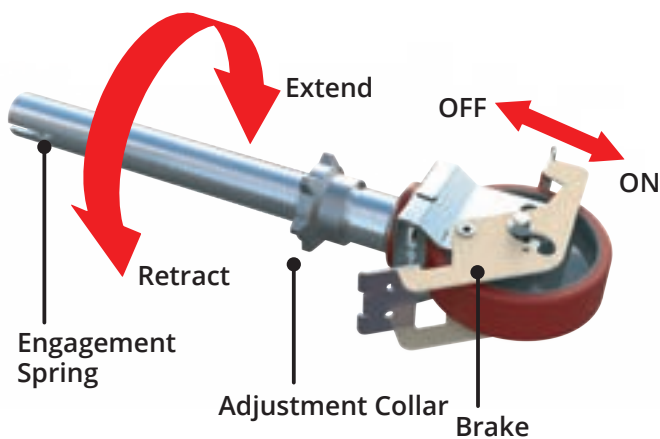

### 7 ADJUSTABLE LEG AND CASTOR

The adjustable leg and castor allows for accurate positioning of your MI TOWER in relation to your workplace. The leg can be extended or retracted to allow for levelling and the brake must be applied to prevent movement.

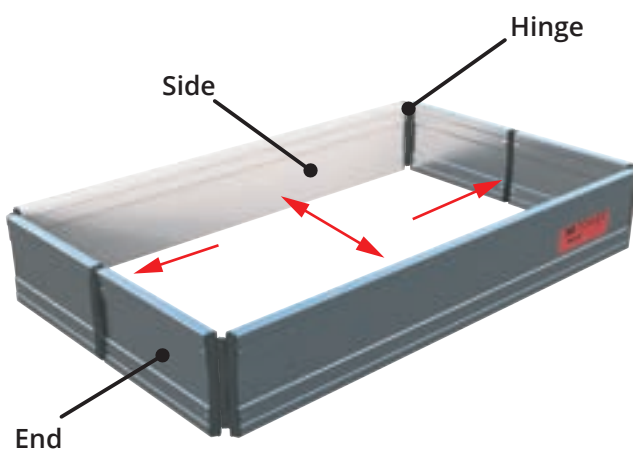

### 8 TOEBOARD

The toeboard, when placed on the working platform, prevents materials and tools from falling from the tower. It consists of folding side and end sections which are articulated via a series of hinges.

It can be opened and fitted over the platform edges by first unfolding the ends and sides as shown in the image to the left. Once unfolded, place all four lower inside edges over the outer edges of the platform.

## INSPECTION, CARE & MAINTENANCE

Keep all components clean and free from contaminants. If any part becomes contaminated with paint, acid, oils or similar products the tower must not be used until the affected components have been cleaned and re-inspected.

Particular attention should be paid to welded joints and any moving parts, such as brace claws, adjustable leg adjustment collars and stabiliser clamps. Ensure all safety decals are present, intact and readable.

A detailed Inspection Guide is available. To obtain a copy of this guide, please contact POP UP Products.

Threads, hinges and brace claws may be lubricated with light oil to ensure correct functionality is maintained. Ensure oil does not contaminate climbing or walking surfaces.

All components should be stored in a dry location where they will be protected from adverse weather conditions. When storing or transporting, keep frames upright and platforms flat. Do not stack excessively to avoid stress damage.

Please contact POP UP Products for further details on maintenance and repair of your MI TOWER+ components.

# KNOW YOUR KIT LIST AND SPECIFICATIONS

## COMPONENT MATRIX AND WEIGHTS

COMPONENT	Weight (Unit) kg	2m qty	3m qty	4m qty	5m qty	6m qty
4 RUNG FRAME	3.55	6	8	10	12	14
TELESCOPIC OUTRIGGER	4.35	4	4	4	4	4
HATCH PLATFORM	12.20	1	2	2	3	3
GUARDRAIL BRACE PANEL	4.15	4	6	7	9	10
220MM ADJUSTABLE LEG	0.85	4	4	4	4	4
125MM LOCKING CASTOR	2.45	4	4	4	4	4
TOE BOARD SET	6.50	1	1	1	1	1
MI TOWER+ WEIGHT (KG)		87.20	114.80	126.05	153.65	164.90
MAXIMUM UNIFORMLY DISTRIBUTED LOAD		240	240	240	240	240

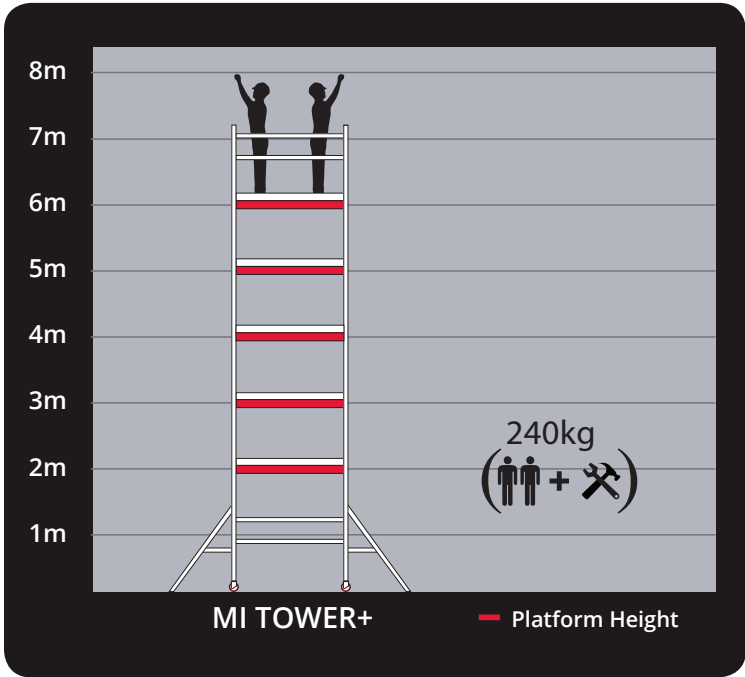

# KNOW YOUR STORAGE AND TRANSPORT PACK

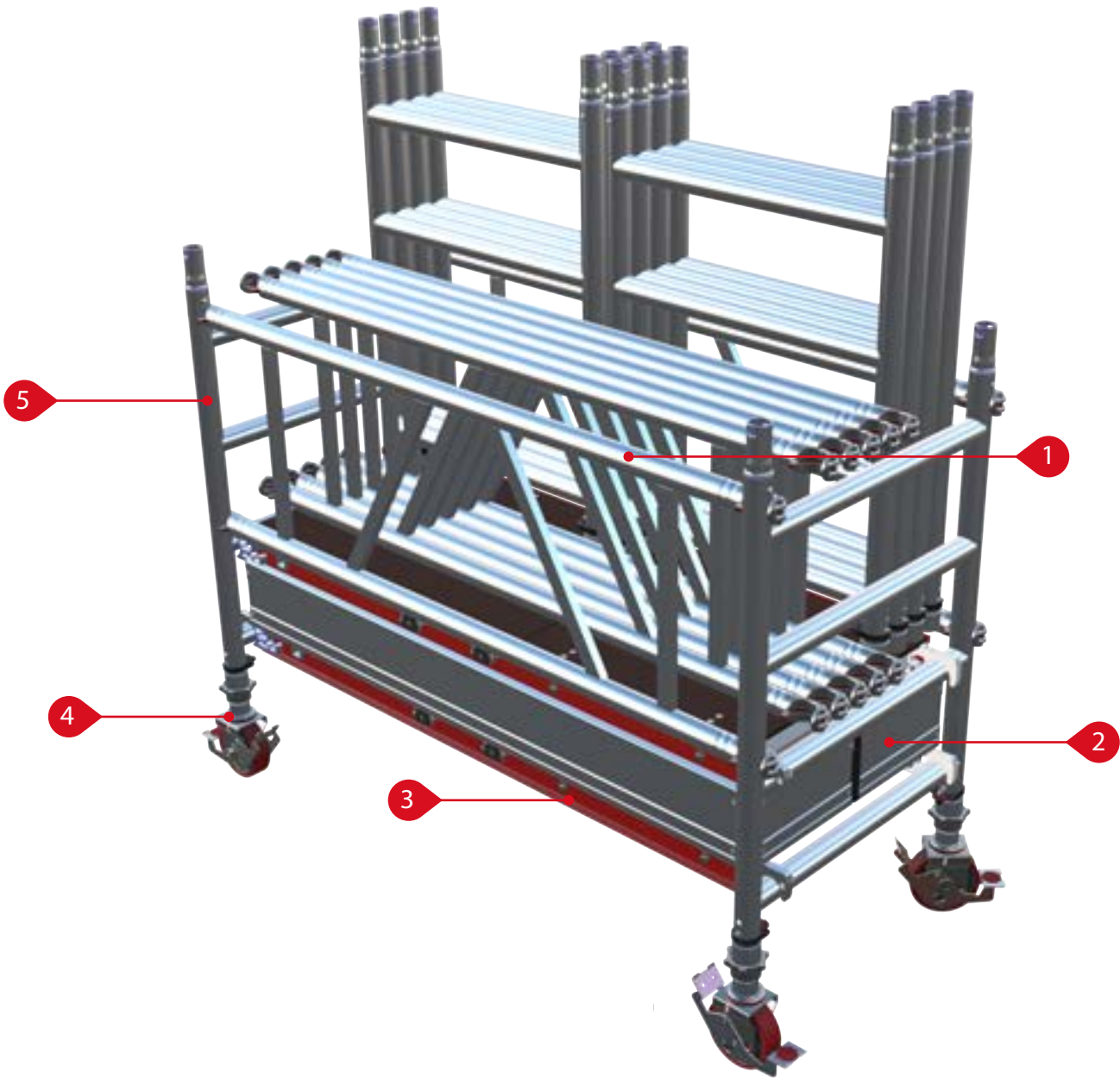

## TRANSPORT AND STORAGE

For ease of storage and of transportation, MI TOWER+ has been designed so that all components can be safely stored within the tower's base assembly. See illustration. Product shown is MI TOWER+ 4m

## TROLLEY COMPONENTS

- 1** GUARDRAIL BRACE PANEL X2
- 2** TOE BOARD SET
- 3** HATCH PLATFORM
- 4** ADJUSTABLE LEG AND CASTOR X4
- 5** 4 RUNG FRAME X2

## SAFETY DOS AND DON'TS - ALWAYS

- 1 Always read and understand this guide before you begin assembly.
- 2 Always ensure that all safety requirements are met and that MI TOWER+ is the correct access solution for the task you wish to perform.
- 3 Always ensure that MI TOWER+ is assembled and dismantled by a qualified, competent person.
- 4 Always cordon off the work area creating a zone with a radius that is 1m greater than the total height of MI TOWER+.
- 5 Always wear the correct Personal Protective Equipment for the task being performed. Gloves, steel toecap boots, a hard hat and suitable clothing must be worn by all persons.
- 6 Always tie back long hair and remove items of loose jewellery.
- 7 Always perform a full risk assessment prior to assembling or using MI TOWER and abide by your findings.
- 8 Always prevent access to unauthorised persons if you have no other option but to leave MI TOWER+ unattended and if this is not possible then MI TOWER must be dismantled.
- 9 Always make tools and materials required for the assembly of your MI TOWER+ are made available on site.
- 10 Always ensure you properly assess the risk/method if tools or materials are hoisted to the platform via a rope.
- 11 Always access platforms from within MI TOWER+ and via the 4 rung frames positioned at the platform's trap door end. Keep your feet in the middle of the rungs and grip the upper rungs with your hands.
- 12 Always erect MI TOWER+ on smooth level ground that is capable of supporting its own weight, the user and any tools or materials without subsidence and free of obstructions.
- 13 Always use your MI TOWER+ in accordance with the instructions contained within this assembly guide.
- 14 Always use your MI TOWER+ in accordance with National Regulations.
- 15 Always remove persons and loose materials from your MI TOWER+ before attempting to move it.

## SAFETY DOS AND DON'TS - NEVER

- 1 Never use MI TOWER+ if you don't understand something in this guide; please contact the supplier for advice.
- 2 Never assemble, use, move or dismantle MI TOWER+ if you are tired or unwell or if you are under the influence of alcohol or drugs.
- 3 Never use MI TOWER+ in adverse weather conditions which may endanger the user.
- 4 Never use in wind conditions of Beaufort Force 5 and above. Please be aware of the tunnel effect caused by buildings close to each other. Dismantle the MI TOWER+ if wind reaches Beaufort 6.
- 5 Never assemble or use MI TOWER+ near overhead hazards such as power lines that are within reach of MI TOWER+ or the user.
- 6 Never ascend or descend your MI TOWER+ if both hands are not free.
- 7 Never add banners, notice boards, etc. to MI TOWER+ or suspend weights from the tower.
- 8 Never use MI TOWER+ if contaminated by paint, chemicals, etc.
- 9 Never overload the platforms (see page 2 for details).
- 10 Never suspend MI TOWER+ from another structure.
- 11 Never lean from MI TOWER+ and never apply undue side force (max 200N)
- 12 Never stand on the guardrails, toe boards, boxes (or similar) to gain extra height. If the working height is insufficient either construct MI TOWER+ to the required height or use an alternative method.
- 13 Never use damaged components in your MI TOWER+ assembly.
- 14 Never use more than one working platform in your MI TOWER+.
- 15 Never allow more than one person on a working platform.
- 16 Never use MI TOWER+ as a means to enter or exit other structures, or as a means of edge protection.
- 17 Never exceed a distance between platforms of 2.0m except for the first platform which can be 3.4m from the ground.
- 18 Never bridge between towers or other structures.
- 19 Never stand on an unguarded platform.
- 20 Never move the tower with people or materials on it.
- 21 Never lift the tower with mechanical equipment.
- 22 Never climb the outside of the tower.

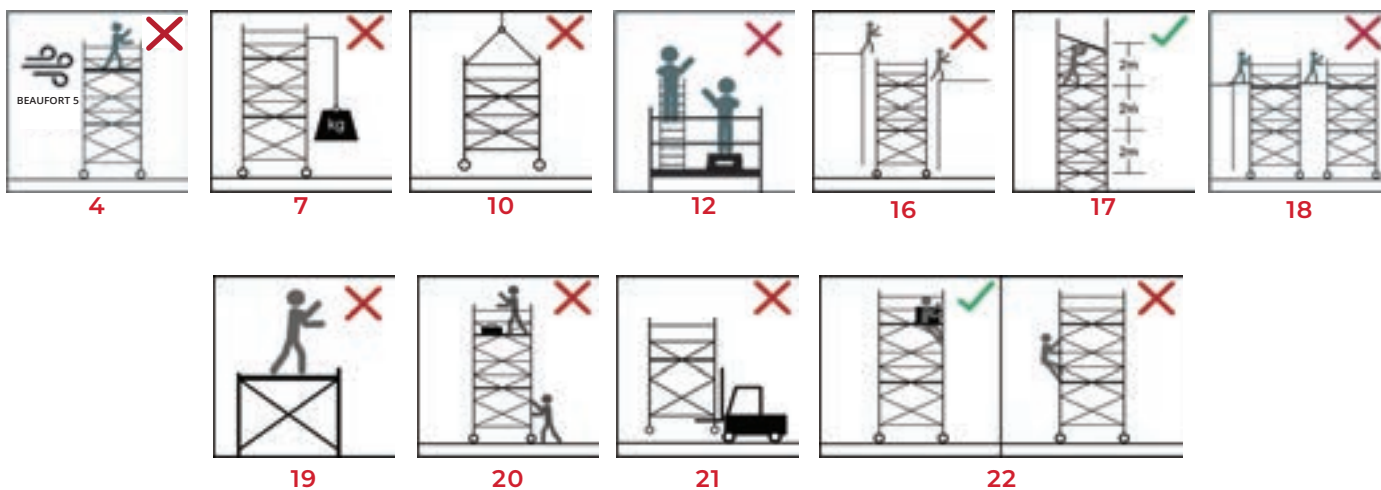

# BEFORE YOU START

## PREPARATION

The floor area must be clear of any obstructions including materials and debris. Check that you have all the components necessary to construct the tower height you require. Check also each component for condition and correct function. If any part is missing or damaged/not working correctly it must be replaced before assembling. Assess the height of tower required before attempting assembly. Refer to component matrices on page 6 for the correct component quantities and if required, ballast for the chosen platform height. Please note working height is generally calculated as two meters above platform height.

## 3T (THROUGH THE TRAPDOOR) SYSTEM

The 3T method of construction has been developed to reduce the risk of an erector falling from a tower during construction. The erector must sit on the platform with legs through the hatch and feet on the frame rungs when attaching guardrail brace panels above the platform. This ensures the erector is always protected by a set of guardrail brace panels.

## TYING IN

You should consider tying in the tower to add stability, but this may only be carried out by a suitably trained person.

## BALLAST

Where shown in the component matrices, ballast must be used to stabilise against overturning. Only use solid materials as ballast (i.e. no loose materials) and position to avoid overloading individual components. Ballast should be attached to the horizontal rungs of your MI TOWER+ and be either securely fastened or be of a design to prevent accidental removal. An example of such ballast is shown below. The quantity of ballast is shown in the component matrices on page 6.

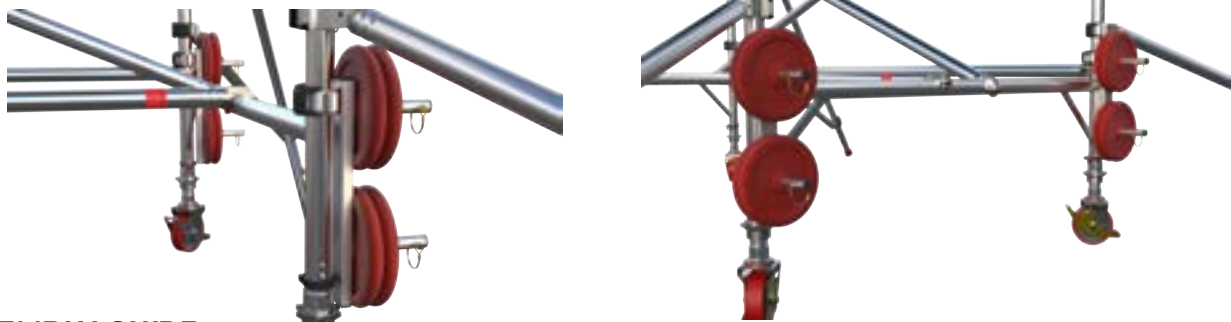

## ASSEMBLY GUIDE

These instructions must always be made available to the user. If replacement copies are required, please contact your supplier. This assembly guide is to be made available on the location of use of this MI TOWER+.

## DAMAGED COMPONENTS

Regularly inspect all components for damage. Damaged components must be quarantined so that they cannot be used. Where safe to do so, the component can be repaired but only by a qualified repairer. If in doubt contact your supplier for advice.

## DISMANTLING YOUR EIGERTOWER

MI TOWER+ is easily dismantled by simply reversing the erection procedure. Make sure that the component hangers are evenly loaded to ensure your MI TOWER+ remains balanced. You must, however, be protected by guardrail brace panels when standing on any platform and ensure that you use the 3T method when removing guardrail brace panels.

## AFTER ASSEMBLY

After assembly the following information needs to be displayed on the access tower and should be clearly visible from the ground (e.g. on a Scafftag).

- The name & contact details of the responsible person
- If the tower is ready for application or not.
- The load class and Uniformly Distributed Load.
- If the access tower is intended for indoor use only.
- The date of assembly.

# GETTING STARTED

## GETTING STARTED

MI TOWER+ requires only one person to assemble and dismantle it. Your MI TOWER is supplied with uniform 1m high rung frames which can be used at any stage of the assembly. During erection, the frames may be connected together to create 2m high frames which makes assembly both quicker and easier.

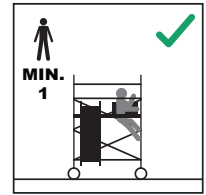

## STABILISER POSITIONING

Stabilisers are supplied and must be used for all MI TOWER+ heights.

For maximum effect arrange the stabilisers by positioning at an angle of 45 degrees to give a footprint as close to square as possible, as shown in fig.1.

If the tower is to be positioned against a wall, the stabiliser footprint can be altered as shown in figs. 2 & 3, but only where the heights of the wall is a minimum of two thirds the height of the top working platform. Ensure that all four stabilisers' feet are in contact with the ground and that the ground can support the weight of the tower and stabilisers.

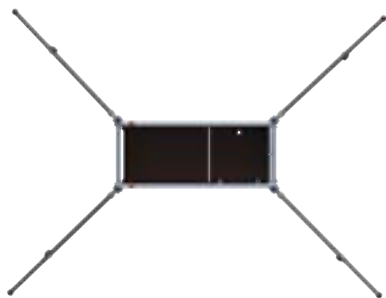

Fig. 1

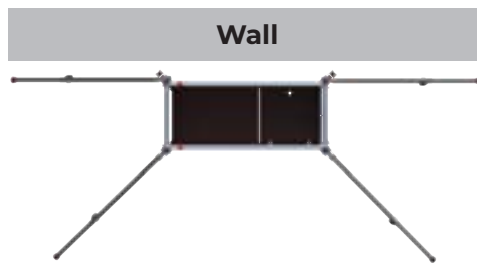

Fig. 2

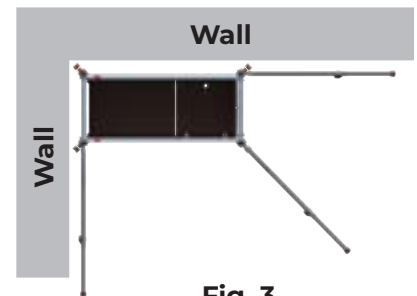

Fig. 3

## MOVING YOUR MI TOWER+

When your MI TOWER+ needs to be moved a small distance to enable you to continue your task, this can be achieved provided the stabilisers can remain in pattern and all tools, materials and personnel are removed from the tower. Assess the route of travel, avoiding overhead obstacles such as power lines before moving your MI TOWER+.

You will need to raise the stabilisers so they are no more than 25mm above the floor and properly locked.

However, if the stabilisers have to be repositioned and this reduces the footprint, your MI TOWER+ must be reduced in height to 2m.

You must only move MI TOWER+ by manual effort, at a slow pace and only after fully assessing the risk. Once moved, always check MI TOWER+ before using ensuring it is level within the inclination of 1% before using it.

If MI TOWER+ is to be moved to a new location, a new level or over rough terrain, it must be fully dismantled and rebuilt at the new location. Your MI TOWER+ is only to be moved on flat obstacle free solid ground (0% Slope).

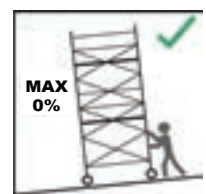

# MI TOWER+ 2m - ASSEMBLY

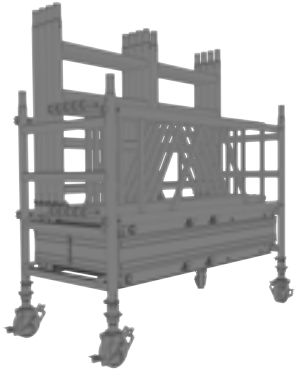

## STEP 1 FROM TROLLEY

For ease of storage and transportation your MI TOWER+ is designed so that all the components can be safely stored within the tower's base. Start by removing the free-standing components from within the trolley and stack safely nearby for use. Remove one of the guardrail brace panels and the hatch platform and store these with the other components. Level the base within 1% inclination as described in Step 2 and move to Step 3.

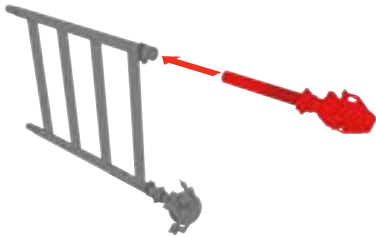

## STEP 1 FROM COMPONENTS

Fully insert the adjustable legs with castors into two frames, turning the leg's height adjustment collar to bring each leg 25mm from the lowest position.

## STEP 2

Attach a guardrail brace panel to the vertical tube of one frame with the upper claw positioned above the fourth rung and with all claws facing outward. Make sure the claws are correctly locked on to the frame tube. Now attach the second frame to the guardrail brace panel to create the base frame assembly. Lock all four castors and using a spirit level as a guide, adjust each leg to bring the base square and level to within 1% of inclination. Do not use the adjustable legs of the wheels to increase the height of the tower. Only use the adjustable legs to level the tower. Make sure that the distance from the ground to the first step does not exceed 400 mm. If necessary, an additional step can be added (306017)



## STEP 3

Construct two sets of conjoined frames, these will give you two 2m sections and will speed up the erection process. Release the frame clips on one four rung frame and fit it on to a second four rung frame. Apply the frame clips and ensure they are correctly locked. Repeat this with the second set. Fit one set of conjoined frames to a base frame and apply the frame clips. Repeat this with the second set.



## STEP 4

Next, attach one guardrail brace panel with its lower jaw positioned above the fifth frame rung. It must be fitted on the opposite side to the first guardrail brace panel to ensure stability. Ensure all claws are facing outward and correctly locked on to the frame tube.

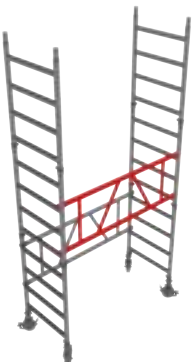

## MI TOWER+ 2m - ASSEMBLY



### STEP 5

Stand inside the tower and fit a platform on to the eighth rung, making sure that the wind-lock catches engage.



### STEP 6

Fit a stabiliser to each corner of the tower. Position the lower horizontal stabiliser coupling clamp just above the frame's second rung, then secure the top stabiliser coupling clamp just above the frame's fifth rung. Adjust the stabilisers so that you create as square a footprint as possible. Adjust each stabiliser's length so that they are in contact with the ground. Make sure all coupling clamps are correctly secured.



### STEP 7

Extend and lock the four component hangers located on either side of the platform. Place two guardrail brace panels on to one set of hangers, and the toe board set on to the opposite side.

Enter the tower framework and climb the frame rungs until you are half way through the platform's trap door. Now manoeuvre yourself so that you are sitting on the platform, with your legs through the trap door and your feet on the frame rungs. From this position, you should take each of the guardrail brace panels, one at a time, and attach so that the upper jaws are positioned above the uppermost rung.



### STEP 8

With both guardrail brace panels in position, you may access the platform. Unfold the toe board set and position so that it sits on the outer edge of the platform. Finally, retract all hangers and the tower is now complete and ready to use.

# MI TOWER+ 3m - ASSEMBLY

## STEP 1

### REPLICATE STEPS 1 FROM 2M BUILD.



Attach a guardrail brace panel to the vertical tube of one frame with the lower claw positioned above the first rung and the claws facing outward. Make sure the claws are correctly locked on to the frame tube. Now attach the second frame to the guardrail brace panel to create the base frame assembly. Lock all four castors and using a spirit level as a guide, adjust each leg to bring the base square and level to within 1% of inclination.

Only use the adjustable legs to level the tower. Make sure that the distance from the ground to the first step does not exceed 400 mm. If necessary, an additional step can be added (306017)



## STEP 2

Fit a platform on to the fourth rung, making sure that the wind-lock catches engage. Next fit a single 1m frame to a base frame and apply the frame clips, then fit a second 1m frame to the base frame and apply the frame clips.



## STEP 3

Next, attach a pair of guardrail brace panels opposite each other with their upper jaws positioned above the uppermost frame rung. Ensure all claws are facing outward and correctly locked on to the frame tube.

## STEP 4

Fit a stabiliser to each corner of the tower. Position the lower horizontal stabiliser coupling clamp just above the frame's second rung, and then secure the top stabiliser coupling clamp just above the frames fifth rung. Adjust the stabilisers so that you create as square a footprint as possible. Adjust each stabiliser's length so that they are in contact with the ground. Make sure all coupling clamps are correctly secured.

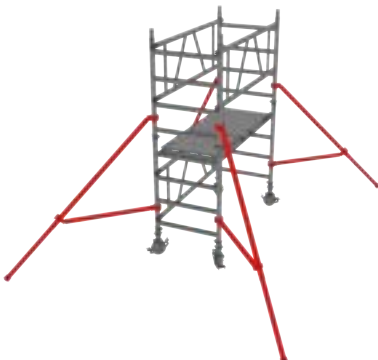

# MI TOWER+ 3m - ASSEMBLY



## STEP 5

Place a set of conjoined frames one at each end of the tower ready to be fitted. Extend and lock the four component hangers located on either side of the first platform. Place a guardrail brace panel on to a component hanger on one side of the platform and a second platform on the other side.

Access the first platform. Fit one set of conjoined frames to each end of the tower and apply the frame clips. Next, attach the guardrail brace panel with its lower jaw positioned above the ninth frame rung. Ensure all claws are facing outward and correctly locked on to the frame tube. Now carefully fit the second platform on to the twelfth rung, making sure that the wind-lock catches engage. Extend and lock the four component hangers located on either side of the platform.

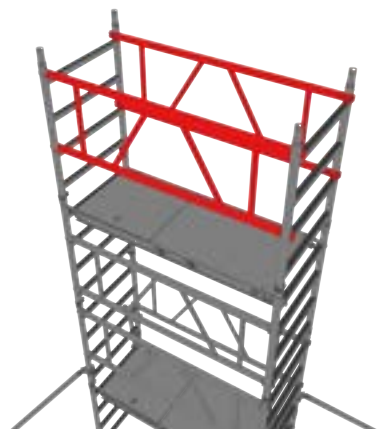

## STEP 6

Descend the tower and from the ground place two guardrail brace panels onto the hangers on one side of the higher platform and a toe board set on the other side.

Access the tower until you are half way through the second platform's trap door. Now manoeuvre yourself so that you are sitting on the platform, with your legs through the trap door and your feet on the frame rungs. From this position, you should take each of the guardrail brace panels, one at a time, and attach so that the upper jaws are positioned above the uppermost rung.

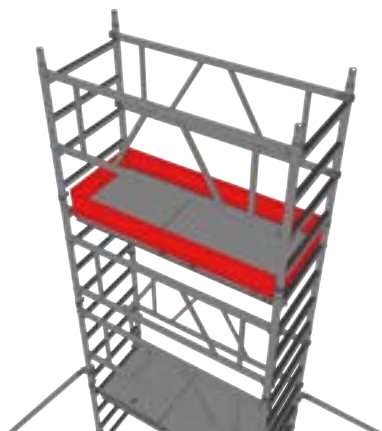

## STEP 7

With both guardrail brace panels in position, you may access the platform. Unfold the toe board set and position so that it sits on the outer edge of the platform. Finally, retract all hangers and the tower is now complete and ready to use.

# MI TOWER+ 4m - ASSEMBLY

## STEP 1

REPLICATE STEPS 1 TO 7 FROM 2M BUILD.

## STEP 2

Extend and lock the four component hangers located on either side of the platform. From the ground place three guardrail brace panels onto the hangers on one side of the platform and two sets of conjoined four rung frames on the other side.

Access the first platform. Fit one set of conjoined frames to each end of the tower and apply the frame clips. Next, attach the guardrail brace panel with its lower jaw positioned above the thirteenth frame rung. Ensure all claws are facing outward and correctly locked on to the frame tube.

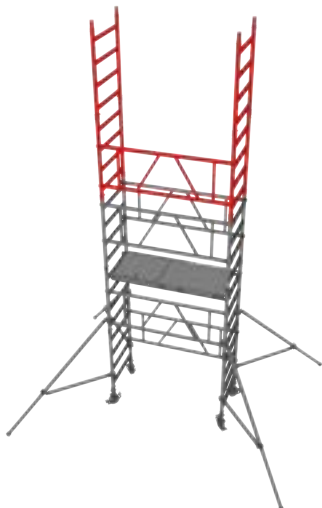

## STEP 3

Descend the tower and from the ground place two guardrail brace panels onto the hangers on one side of the platform and a toe board set and a platform on the other side.

Access the first platform and carefully fit the second platform on to the sixteenth rung, making sure that the wind-lock catches engage. Next extend and lock the four component hangers located on either side of the second platform. Move the two guardrail brace panels from the hangers on the first platform on to the hangers of the second platform and then repeat the process with the toeboard set on the other side of the platform.

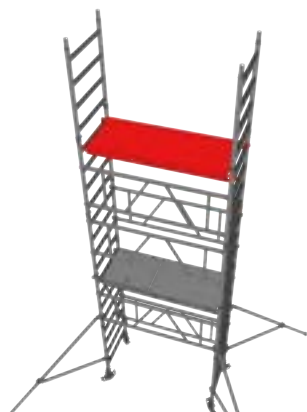

## STEP 4

Access the tower until you are half way through the second platform's trap door. Now manoeuvre yourself so that you are sitting on the platform, with your legs through the trap door and your feet on the frame rungs. From this position, you should take each of the guardrail brace panels, one at a time, and attach so that the upper jaws are positioned above the uppermost rung.

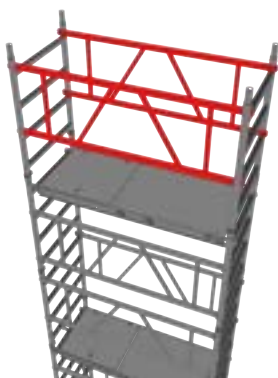

## MITOWER+4m - ASSEMBLY

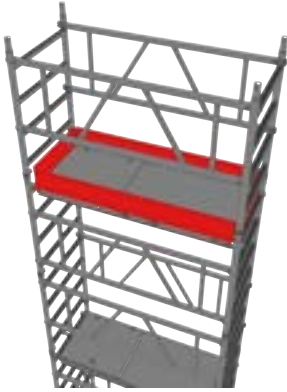

### **STEP 5**

With both guardrail brace panels in position, you may access the platform. Unfold the toe board set and position so that it sits on the outer edge of the platform. Finally, retract all hangers and the tower is now complete and ready to use.

# MI TOWER+ 5m - ASSEMBLY



## STEP 1

### REPLICATE STEPS 1 TO 6 FROM 3M BUILD.

Access the second platform and fit a set of conjoined frames to each end of the tower and apply the frame clips. Next, attach the guardrail brace panel with its lower jaw positioned above the seventeenth frame rung. Ensure all claws are facing outward and correctly locked on to the frame tube.



## STEP 2

Descend the tower and from the ground place two guardrail brace panels onto the hangers on one side of the second platform and a toe board set and a platform on the other side.

Access the second platform and carefully fit the third platform on to the twentieth rung, making sure that the wind-lock catches engage. Next extend and lock the four component hangers located on either side of the second platform. Move the two guardrail brace panels from the hangers on the second platform on to the hangers of the third platform and then repeat the process with the toeboard set on the other side of the platform.



## STEP 3

Access the tower until you are half way through the third platform's trap door. Now manoeuvre yourself so that you are sitting on the platform, with your legs through the trap door and your feet on the frame rungs. From this position, you should take each of the guardrail brace panels, one at a time, and attach so that the upper jaws are positioned above the uppermost rung.

## MI TOWER+ 5m - ASSEMBLY

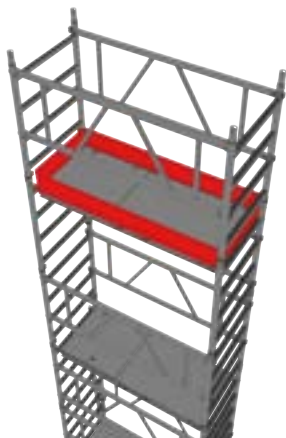

### STEP 4

With both guardrail brace panels in position, you may access the platform. Unfold the toe board set and position so that they sit on to the outer edge of the platform. Finally, retract all hangers and the tower is now complete and ready to use.

# MI TOWER+ 6m - ASSEMBLY

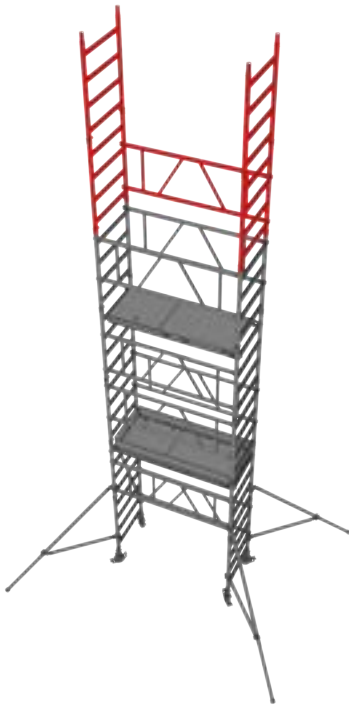

## STEP 1

### REPLICATE STEPS 1 TO 6 FROM 4M BUILD.

Descend the tower and from the ground place three guardrail brace panels onto the hangers on one side of the first platform and two of conjoined four rung frames on the other side.

Access the first platform and move the three guardrail brace panels from the hangers on the first platform on to the hangers of the second platform. Repeat the process with the two sets of conjoined four rung frames. Access the second platform and fit a set of conjoined frames to each end of the tower and apply the frame clips. Next, attach the guardrail brace panel with its lower jaw positioned above the seventeenth frame rung. Ensure all claws are facing outward and correctly locked on to the frame tube.

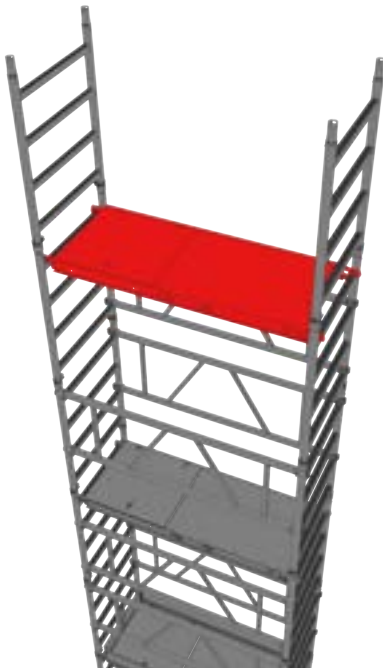

## STEP 2

Descend the tower and from the ground place a toeboard set on to the hangers of the tower platform on the same side that the two guardrail brace panels are hanging. Then place a platform on the hangers on the other side of the lower platform.

Access the first platform and move the toeboard set from the hangers on to the hangers of the second platform.

Repeat the process with the platform on the other side.

Access the second platform and carefully fit the third platform on to the twentieth rung, making sure that the wind-lock catches engage.

Next, extend and lock the four component hangers located on either side of the platform. Move the toeboard set from the hangers on the second platform onto the hangers on the opposite side of the third platform. Then move the two guardrail brace panels up to the hangers on the third platform.

## MI TOWER+ 6m - ASSEMBLY

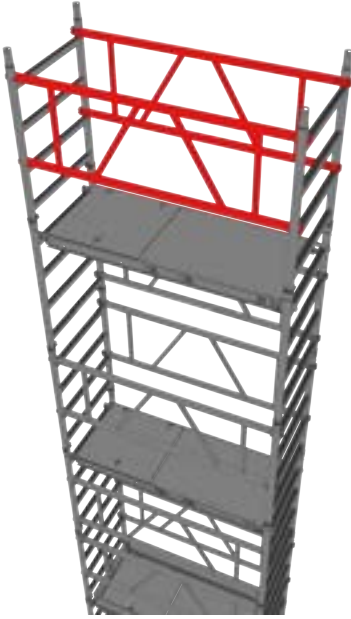

### STEP 3

Access the tower until you are half way through the third platform's trap door. Now manoeuvre yourself so that you are sitting on the platform, with your legs through the trap door and your feet on the frame rungs. From this position, you should take each of the guardrail brace panels, one at a time, and attach so that the upper jaws are positioned above the uppermost rung.

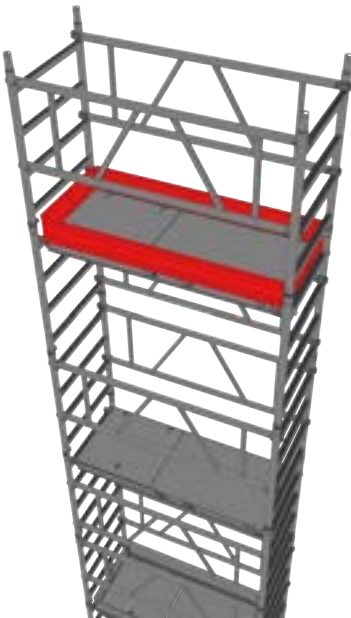

### STEP 4

With both guardrail brace panels in position, you may access the platform. Unfold the toe board set and position so that it sits on the outer edge of the platform. Finally, retract all hangers and the tower is now complete and ready to use.

# 10 POINT PRE-USE SAFETY CHECKLIST

## 10 POINT PRE-USE CHECKLIST FOR USERS

<b>1</b>	<b>BEFORE USE</b>	Ensure tower is correct, complete and level.
<b>2</b>	<b>COMPONENTS</b>	Check all components are free from damage.
<b>3</b>	<b>CASTORS</b>	Ensure the brakes are locked.
<b>4</b>	<b>ENVIRONMENT</b>	No environmental changes have influenced the safe use of your tower.
<b>5</b>	<b>STABILISER COUPLER CLAMPS</b>	Check they are secure & correctly attached.
<b>6</b>	<b>GUARDRAILS</b>	Make sure all platforms are fully enclosed by guardrails.
<b>7</b>	<b>BRACE CLAWS</b>	Check they are locked correctly.
<b>8</b>	<b>WINDLOCK CATCHES</b>	Make sure they are engaged.
<b>9</b>	<b>FRAME CLIPS</b>	Make sure they are engaged.
<b>10</b>	<b>TOE BOARDS</b>	Check they are correctly positioned on the platform.

**REGISTRATIONS**

**ISO 9001**

**EN 1004  
Class 3**





POP UP Products  
Unit E1, Tenth Avenue  
Deeside Industrial Park  
Deeside  
Flintshire  
CH5 2UA